

Notice for TAIYO YUDEN Products

Please read this notice before using the TAIYO YUDEN products.

⚠ REMINDERS

Product Information in this Catalog

Product information in this catalog is as of March 2023. All of the contents specified herein and production status of the products listed in this catalog are subject to change without notice due to technical improvement of our products, etc. Therefore, please check for the latest information carefully before practical application or use of our products.

Please note that TAIYO YUDEN shall not be in any way responsible for any damages and defects in products or equipment incorporating our products, which are caused under the conditions other than those specified in this catalog or individual product specification sheets.

Approval of Product Specifications

Please contact TAIYO YUDEN for further details of product specifications as the individual product specification sheets are available. When using our products, please be sure to approve our product specifications or make a written agreement on the product specification with TAIYO YUDEN in advance.

Pre-Evaluation in the Actual Equipment and Conditions

Please conduct validation and verification of our products in actual conditions of mounting and operating environment before using our products.

Limited Application

1. Equipment Intended for Use

The products listed in this catalog are intended for general-purpose and standard use in general electronic equipment for consumer (e.g., AV equipment, OA equipment, home electric appliances, office equipment, information and communication equipment including, without limitation, mobile phone, and PC) and other equipment specified in this catalog or the individual product specification sheets, or the equipment approved separately by TAIYO YUDEN.

TAIYO YUDEN has the product series intended for use in the following equipment. Therefore, when using our products for these equipment, please check available applications specified in this catalog or the individual product specification sheets and use the corresponding products.

Application	Product Series		Quality Grade ^{*3}
	Equipment ^{*1}	Category (Part Number Code ^{*2})	
Automotive	Automotive Electronic Equipment (POWERTRAIN, SAFETY)	A	1
	Automotive Electronic Equipment (BODY & CHASSIS, INFOTAINMENT)	C	2
Industrial	Telecommunications Infrastructure and Industrial Equipment	B	2
Medical	Medical Devices classified as GHTF Class C (Japan Class III)	M	2
	Medical Devices classified as GHTF Classes A or B (Japan Classes I or II)	L	3
Consumer	General Electronic Equipment	S	3
	Only for Mobile Devices ^{*4}	E	4

*Notes: 1. Based on the general specifications required for electronic components for such equipment, which are recognized by TAIYO YUDEN, the use of each product series for the equipment is recommended. Please be sure to contact TAIYO YUDEN before using our products for equipment other than those covered by the product series.

2. On each of our part number, the 2nd code from the left is a code indicating the "Category" as shown in the above table. For details, please check the explanatory materials regarding the part numbering system of each of our products.

3. Each product series is assigned a "Quality Grade" from 1 to 4 in order of higher quality. Please do not incorporate a product into any equipment with a higher Quality Grade than the Quality Grade of such product without the prior written consent of TAIYO YUDEN.

4. The applications covered by this product series are limited to mobile devices (smartphone, tablet PC, smartwatch, handheld game console, etc.) among general electronic equipment for consumer. The design, specifications and operating environment, etc. differ from those of the product series for "General Electronic Equipment" (Category: S), so please check the individual product specification sheets for details. The product series for "General Electronic Equipment" (Category: S) can also be used for mobile devices.

▶ This catalog contains the typical specification only due to the limitation of space. When you consider the purchase of our products, please check our product specification sheets. For details of each product (characteristics graph, reliability information, precautions for use, and so on), see our website (<http://www.ty-top.com/>).

2. Equipment Requiring Inquiry

Please be sure to contact TAIYO YUDEN for further information before using the products listed in this catalog for the following equipment (excluding intended equipment as specified in this catalog or the individual product specification sheets) which may cause loss of human life, bodily injury, serious property damage and/or serious public impact due to a failure or defect of the products and/or malfunction attributed thereto.

- (1) Transportation equipment (automotive powertrain control system, train control system, and ship control system, etc.)
- (2) Traffic signal equipment
- (3) Disaster prevention equipment, crime prevention equipment
- (4) Medical devices classified as GHTF Class C (Japan Class III)
- (5) Highly public information network equipment, data-processing equipment (telephone exchange, and base station, etc.)
- (6) Any other equipment requiring high levels of quality and/or reliability equal to the equipment listed above

3. Equipment Prohibited for Use

Please do not incorporate our products into the following equipment requiring extremely high levels of safety and/or reliability.

- (1) Aerospace equipment (artificial satellite, rocket, etc.)
- (2) Aviation equipment *1
- (3) Medical devices classified as GHTF Class D (Japan Class IV), implantable medical devices *2
- (4) Power generation control equipment (nuclear power, hydroelectric power, thermal power plant control system, etc.)
- (5) Undersea equipment (submarine repeating equipment, etc.)
- (6) Military equipment
- (7) Any other equipment requiring extremely high levels of safety and/or reliability equal to the equipment listed above

*Notes: 1. There is a possibility that our products can be used only for aviation equipment that does not directly affect the safe operation of aircraft (e.g., in-flight entertainment, cabin light, electric seat, cooking equipment) if such use meets requirements specified separately by TAIYO YUDEN. Please be sure to contact TAIYO YUDEN for further information before using our products for such aviation equipment.

2. Implantable medical devices contain not only internal unit which is implanted in a body, but also external unit which is connected to the internal unit.

4. Limitation of Liability

Please note that unless you obtain prior written consent of TAIYO YUDEN, TAIYO YUDEN shall not be in any way responsible for any damages incurred by you or third parties arising from use of the products listed in this catalog for any equipment that is not intended for use by TAIYO YUDEN, or any equipment requiring inquiry to TAIYO YUDEN or prohibited for use by TAIYO YUDEN as described above.

■ Safety Design

When using our products for high safety and/or reliability-required equipment or circuits, please fully perform safety and/or reliability evaluation. In addition, please install (i) systems equipped with a protection circuit and a protection device and/or (ii) systems equipped with a redundant circuit or other system to prevent an unsafe status in the event of a single fault for a failsafe design to ensure safety.

■ Intellectual Property Rights

Information contained in this catalog is intended to convey examples of typical performances and/or applications of our products and is not intended to make any warranty with respect to the intellectual property rights or any other related rights of TAIYO YUDEN or any third parties nor grant any license under such rights.

■ Limited Warranty

Please note that the scope of warranty for our products is limited to the delivered our products themselves conforming to the product specifications specified in the individual product specification sheets, and TAIYO YUDEN shall not be in any way responsible for any damages resulting from a failure or defect in our products. Notwithstanding the foregoing, if there is a written agreement (e.g., supply and purchase agreement, quality assurance agreement) signed by TAIYO YUDEN and your company, TAIYO YUDEN will warrant our products in accordance with such agreement, provided, however, that our products shall be used for general-purpose and standard use in the equipment specified in this catalog or the individual product specification sheets.

■ TAIYO YUDEN's Official Sales Channel

The contents of this catalog are applicable to our products which are purchased from our sales offices or authorized distributors (hereinafter "TAIYO YUDEN's official sales channel"). Please note that the contents of this catalog are not applicable to our products purchased from any seller other than TAIYO YUDEN's official sales channel.

■ Caution for Export

Some of our products listed in this catalog may require specific procedures for export according to "U.S. Export Administration Regulations", "Foreign Exchange and Foreign Trade Control Law" of Japan, and other applicable regulations. Should you have any questions on this matter, please contact our sales staff.

▶ This catalog contains the typical specification only due to the limitation of space. When you consider the purchase of our products, please check our product specification sheets. For details of each product (characteristics graph, reliability information, precautions for use, and so on), see our website (<http://www.ty-top.com/>).

Ceramic RF Devices for General Electronic Equipment for Consumer

REFLOW

PART NUMBER

T	S	D	1	M	1	5	H	8	2	9	M	L	M	0	D	Z	T	
①	②	③	④	⑤	⑥	⑦	⑧	⑨										

①Series

Code (1)(2)(3)(4)	
TSB1	Ceramic RF Device for General Electronic Equipment for Consumer, Band Pass type
TSC1	Ceramic RF Device for General Electronic Equipment for Consumer, Coupler
TSC4	Ceramic RF Device for General Electronic Equipment for Consumer, Coupler, 2 Branch type
TSD1	Ceramic RF Device for General Electronic Equipment for Consumer, Diplexer
TSH1	Ceramic RF Device for General Electronic Equipment for Consumer, High Pass type
TSL1	Ceramic RF Device for General Electronic Equipment for Consumer, Low Pass type
TST1	Ceramic RF Device for General Electronic Equipment for Consumer, Triplexer

(1) Product Group

Code	
T	Ceramic RF Devices

(2) Category

Code	Recommended equipment	Quality Grade
S	General Electronic Equipment for Consumer	3

(3) Type

Code	
B	Band Pass type
C	Coupler
D	Diplexer
H	High Pass type
L	Low Pass type
T	Triplexer

(4) Features, Characteristics

Code	
1	Standard
4	2 Branch type

②Series name

Code	Series name
N	Standard
M	High performance compact product

③Dimensions (L × W)

Code	Dimensions (L × W) [mm]
22	2.5 × 2.0
21	2.0 × 1.25
18	1.6 × 0.8
15	1.0 × 0.5

④Thickness

Code	Thickness [mm]
A	1.0
C	0.7
D	0.65
F	0.5
G	0.45
H	0.4

⑤Frequency

Code (example)	Frequency [MHz]
2G45	2400 ~ 2500
829M	698 ~ 960

⑥Electrode type

Code	Electrode type
N	External electrode
L	LGA electrode

⑦Internal Code

⑧Packaging

Code	Packaging
T	Taping

⑨Internal Code

EXTERNAL DIMENSIONS / STANDARD QUANTITY

<p>TSB1N21D LGA 3Pins type</p>	<p>TSB1N18F2G45NS001T</p>	<p>TSB1N15H / TSL1N15H Side 4Pins type</p>	<p>TSL1N18D628MNS0M4T</p>
<p>TSB1N18B/TSL1N18D / TSH1N18D LGA 3Pins type</p>	<p>TSD1N18D2G45NS030T</p>	<p>TSD1N21A LGA 6Pins type</p>	<p>TSD1N21C LGA 6Pins type</p>
<p>TSD1N18B LGA 6Pins type</p>	<p>TSD1M15H829MLM0DZT</p>	<p>TST1N22D LGA 9Pins type</p>	<p>TSC1N18D1G68NC0AAT</p>
<p>TSC4N18F1G69NS0B1T</p>			

Unit: mm

	TSB1N21D LGA 3Pins type	TSL1N18D628MNS0M4T	TSL1N18D / TSH1N18D LGA 3Pins type	TSD1N18D2G45NS030T	TSD1N21A829MLS0G2T TSD1N21A829MLV0H9T TSD1N21A1G95LV0ENT TSD1N21C1G70LV0CLT	TSD1N21A829MLV0JTT TSD1N21C1G70LV0HUT
(1)	RF IN/OUT	I/O Port	RF IN/OUT	GND	Low Band	High Band
(2)	GND	GND	GND	Common	GND	GND
(3)	RF IN/OUT	I/O Port	RF IN/OUT	GND	High Band	Low Band
(4)	-	GND	-	Low Band	GND	GND
(5)	-	GND	-	GND	Common Port	Common Port
(6)	-	GND	-	High Band	GND	GND
(7)	-	-	-	-	-	-
(8)	-	-	-	-	-	-

	TSD1N18B829MLV0D4T TSD1N18B1G79LS0FHT	TSD1N18B829MLV0CZT	TSD1M15H829MLM0DZT	TST1N22D829MLV0H2T	TSC1N18D1G68NC0AAT	TSC4N18F1G69NS0B1T
(1)	GND	GND	High Band	High Band	CPL	RF1 IN/OUT
(2)	Common Port	Common Port	Common Port	GND	GND	CPL2 RF1
(3)	GND	GND	Low Band	Mid Band	Isolation	CPL2 RF2
(4)	High Band	Low Band	Low Band	GND	RF OUT	GND
(5)	GND	GND	GND	Low Band	GND	RF2 OUT/IN
(6)	Low Band	High Band	High Band	GND	RF IN	CPL1 RF2
(7)	-	-	-	Common Port	-	CPL1 RF1
(8)	-	-	-	GND	-	GND
(9)	-	-	-	GND	-	-

Type	Standard quantity [pcs]
22	3000
21	3000~6000
18	4000~8000
15	10000

PART NUMBER

● Band Pass type

Applications	External dimensions [mm]	New part number	Old part number (for reference)	Notes
2.4GHz W-LAN / Bluetooth®	1.6 × 0.8 × 0.5max.	TSB1N18F2G45NS001T	FI 168B245001-T	Side 4Pins
	1.0 × 0.5 × 0.4max.	TSB1N15H2G45NS024T	FI 105B245024-T	Side 4Pins
5GHz W-LAN	1.6 × 0.8 × 0.65max.	TSB1N18D5G53LV0HBT	FI 168B5538HB-T	LGA 3Pins
5G NR Sub 6	2.0 × 1.25 × 0.65max.	TSB1N21D3G75LV0EQT	FI 212B3750EQ-T	LGA 3Pins
	2.0 × 1.25 × 0.65max.	TSB1N21D4G70LV0DQT	FI 212B4700DQ-T	LGA 3Pins
	2.0 × 1.25 × 0.65max.	TSB1N21D4G15LV0HWT	FI 212B4150HW-T	LGA 3Pins

● Low Pass type

Applications	External dimensions [mm]	New part number	Old part number (for reference)	Notes
Cellular	1.0 × 0.5 × 0.4max.	TSL1N15H1G86NS022T	FI 105L186822-T	Side 4Pins
	1.0 × 0.5 × 0.4max.	TSL1N15H829MLS0G2T	FI 105L0829GZ-T	LGA 6Pins
	1.0 × 0.5 × 0.4max.	TSL1N15H1G72LV0FLT	FI 105L1726FL-T	LGA 6Pins
	1.6 × 0.8 × 0.65max.	TSL1N18D628MNS0M4T	FI 168L0628M4-T	Side 6Pins
	1.6 × 0.8 × 0.65max.	TSL1N18D829MLV0FDT	FI 168L0829FD-T	LGA 3Pins
	1.6 × 0.8 × 0.65max.	TSL1N18D1G86LC0EDT	FI 168L1868ED-T	LGA 3Pins
	1.6 × 0.8 × 0.65max.	TSL1N18D2G20LS0G9T	FI 168L2200G9-T	LGA 3Pins
	1.6 × 0.8 × 0.65max.	TSL1N18D1G68LS0G6T	FI 168L1681G6-T	LGA 3Pins
	1.6 × 0.8 × 0.65max.	TSL1N18D1G68LV0DTT	FI 168L1681DT-T	LGA 3Pins

● High Pass type

Applications	External dimensions [mm]	New part number	Old part number (for reference)	Notes
Cellular	1.6 × 0.8 × 0.65max.	TSH1N18D2G49LS0FBT	FI 168H2495FB-T	LGA 3Pins

● Diplexer

Applications	External dimensions [mm]	New part number	Old part number (for reference)	Notes
W-LAN	1.6 × 0.8 × 0.65max.	TSD1N18D2G45NS030T	FI 168P245030-T	Side 6Pins
Cellular 4G , 5G NR	2.0 × 1.25 × 1.0max.	TSD1N21A829MLS0G2T	FI 212P0829G2-T	LGA 6Pin
	2.0 × 1.25 × 1.0max.	TSD1N21A829MLV0H9T	FI 212P0829H9-T	LGA 6Pin
	2.0 × 1.25 × 1.0max.	TSD1N21A829MLV0JJT	FI 212P0829JJ-T	LGA 6Pin
	1.6 × 0.8 × 0.8max.	TSD1N18B829MLV0D4T	FI 168P0829D4-T	LGA 6Pin
	1.6 × 0.8 × 0.8max.	TSD1N18B829MLV0CZT	FI 168P0829CZ-T	LGA 6Pin
	1.0 × 0.5 × 0.4max.	TSD1M15H829MLMODZT	FQ 105P0829DZ-T	LGA 6Pin
	1.6 × 0.8 × 0.8max.	TSD1N18B1G79LS0FHT	FI 168P1795FH-T	LGA 6Pin
	2.0 × 1.25 × 1.0max.	TSD1N21A1G95LVOENT	FI 212P1955EN-T	LGA 6Pin
	2.0 × 1.25 × 0.7max.	TSD1N21C1G70LV0CLT	FI 212P1700CL-T	LGA 6Pin
	2.0 × 1.25 × 0.7max.	TSD1N21C1G70LV0HUT	FI 212P1700HU-T	LGA 6Pin

● Triplexer

Applications	External dimensions [mm]	New part number	Old part number (for reference)	Notes
Cellular 4G , 5G NR	2.5 × 2.0 × 0.65max.	TST1N22D829MLV0H2T	FI 252M0829H2-T	LGA 9Pin

● Coupler

Applications	External dimensions [mm]	New part number	Old part number (for reference)	Notes
Cellular	1.6 × 0.8 × 0.5max.	TSC4N18F1G69NS0B1T	FI 168W1697B1-T	Side 8Pins
	1.6 × 0.8 × 0.65max.	TSC1N18D1G68NCOAAT	FI 168K1687AA-T	Side 6Pins

ELECTRICAL CHARACTERISTICS / TYPICAL CHARACTERISTICS

TSB1N18F2G45NS001T

Pass band frequency	2400 - 2500 MHz
Insertion loss at pass band	2.2 dB max. (+25°C)
	2.5 dB max. (-40~+85°C)
Ripple at pass band	1.0 dB max.
V.S.W.R. at pass band	2.1 max.
Attenuation	25 dB min. (800 - 960 MHz)
	25 dB min. (1710 - 1910 MHz)
	20 dB min. (4800 - 5000 MHz)
	20 dB min. (7200 - 7500 MHz)
Impedance	50 Ω

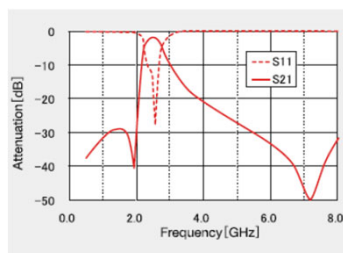

TSB1N15H2G45NS024T

Pass band frequency	2400 - 2500 MHz
Insertion loss at pass band	3.0 dB max. (+25°C)
	3.3 dB max. (-40~+85°C)
Ripple at pass band	1.0 dB max.
V.S.W.R. at pass band	2.2 max.
Attenuation	25 dB min. (800 - 960 MHz)
	22 dB min. (1710 - 1910 MHz)
	20 dB min. (4800 - 5000 MHz)
	20 dB min. (7200 - 7500 MHz)

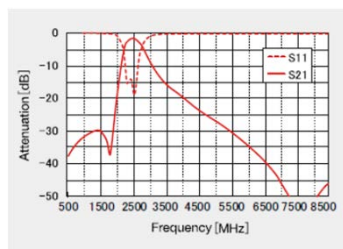

TSB1N18D5G53LV0HBT

Pass band frequency	5150 - 5925 MHz
Insertion loss at pass band	1.4 dB max. (+25°C)
	1.5 dB max. (-40~+85°C)
V.S.W.R. at pass band	2.0 max.
Attenuation	35 dB min. (700 - 2690 MHz)
	28 dB min. (3300 - 4200 MHz)
	20 dB min. (7200 - 7800 MHz)
Impedance	50 Ω

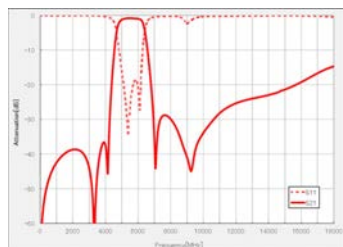

TSB1N21D3G75LV0EQT

Pass band frequency	3300 - 4200 MHz
Impedance	50 Ω

TSB1N21D4G70LV0DQT

Pass band frequency	4400 - 5000 MHz
Impedance	50 Ω

TSB1N21D4G15LV0HWT

Pass band frequency	3300 - 5000 MHz
Impedance	50 Ω

TSL1N15H1G86NS022T

Pass band frequency	1710 - 2025 MHz
Insertion loss at 1710 - 2025 MHz	0.65 dB max. (-40~+85°C)
V.S.W.R. at 1710 - 2025 MHz	1.7 max.
Attenuation	22 dB min. (3420 - 3820 MHz)
	25 dB min. (3820 - 6075 MHz)
Impedance	50 Ω

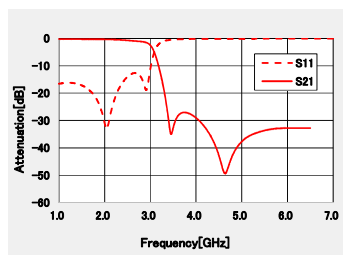

ELECTRICAL CHARACTERISTICS / TYPICAL CHARACTERISTICS

TSL1N15H829MLS0GZT

Pass band frequency	617 - 960 MHz
Insertion loss at 617 - 960 MHz	0.9 dB max. (+25°C)
	0.95 dB max. (-40~+85°C)
V.S.W.R. at 617 - 960 MHz	2.0 max.
Attenuation	35 dB min. (1805 - 1830 MHz)
	35 dB min. (2110 - 2170 MHz)
	30 dB min. (1710 - 2700 MHz)
Impedance	50 Ω

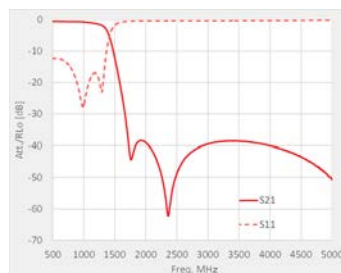

TSL1N15H1G72LV0FLT

Pass band frequency	1426 - 2200 MHz
Insertion loss at 1426 - 2200 MHz	0.65 dB max. (+25°C)
	0.75 dB max. (-40~+85°C)
V.S.W.R. at 1426 - 2200 MHz	2.0 max.
Attenuation	15 dB min. (3300 - 4200 MHz)
	25 dB min. (3400 - 3800 MHz)
	25 dB min. (4200 - 5000 MHz)
	25 dB min. (5150 - 5850 MHz)
Impedance	50 Ω

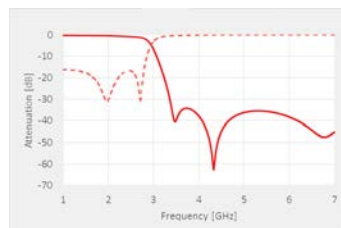

TSL1N18D628MNS0M4T

Pass band frequency	470 - 787 MHz
Insertion loss at pass band	0.5 dB max. (+25°C)
	0.6 dB max. (-40~+85°C)
V.S.W.R. at pass band	2.0 max.
Attenuation	26 dB min. (1429 - 1501 MHz)
	30 dB min. (1565 - 1607 MHz)
	35 dB min. (1570 - 1580 MHz)
	18 dB min. (1920 - 1980 MHz)
Impedance	50 Ω

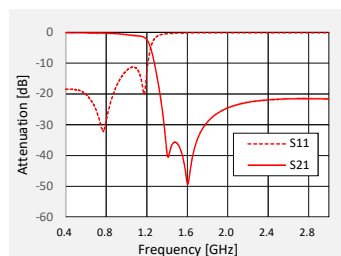

TSL1N18D829MLV0FDT

Pass band frequency	698 - 960 MHz
Insertion loss at 698 - 960 MHz	0.4 dB max. (+25°C)
	0.45 dB max. (-40~+85°C)
V.S.W.R. at 698 - 960 MHz	2.0 max.
Attenuation	15 dB min. (1554 - 1610 MHz)
	21 dB min. (1760 - 1830 MHz)
	30 dB min. (2400 - 5950 MHz)
Impedance	50 Ω

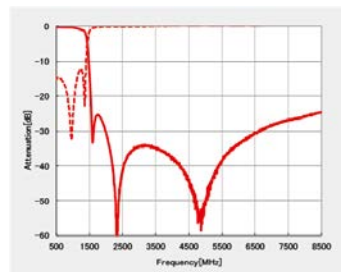

TSL1N18D1G86LC0EDT

Pass band frequency	1710 - 2025 MHz
Insertion loss at 1710 - 2025 MHz	0.4 dB max. (+25°C)
	0.5 dB max. (-40~+85°C)
V.S.W.R. at 1710 - 2025 MHz	2.0 max.
Attenuation	27 dB min. (3420 - 3840 MHz)
	28 dB min. (4020 - 4050 MHz)
	20 dB min. (4900 - 5950 MHz)
Impedance	50 Ω

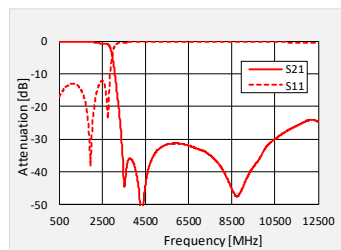

ELECTRICAL CHARACTERISTICS / TYPICAL CHARACTERISTICS

TSL1N18D2G20LS0G9T

Pass band frequency	1700 – 2170 MHz 2170 – 2500 MHz 2500 – 2700 MHz
Insertion loss at 1700 – 2170 MHz	0.5 dB max. (+25°C) 0.55 dB max. (-40~+90°C)
Insertion loss at 2170 – 2500 MHz	0.65 dB max. (+25°C) 0.75 dB max. (-40~+90°C)
Insertion loss at 2500 – 2700 MHz	0.9 dB max. (+25°C) 1.0 dB max. (-40~+90°C)
Return loss. at 1700 – 2700 MHz	10 dB min.
Attenuation	25 dB min. (3400 MHz) 22 dB min. (3400 – 5400 MHz) 20 dB min. (5400 – 8100 MHz)
Impedance	50 Ω

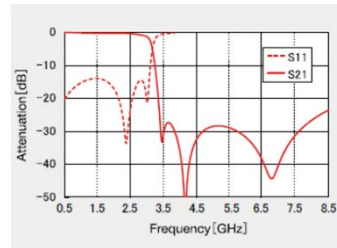

TSL1N18D1G68LS0G6T

Pass band frequency	617 – 2690 MHz 0.5 dB max. (-40~+90°C)
Return loss. at 617 – 2690 MHz	10 dB min.
Attenuation	35 dB min. (4950 – 6000 MHz) 35 dB min. (6000 – 7500 MHz) 35 dB min. (7500 – 8100 MHz) 35 dB min. (8100 – 10500 MHz) 27 dB min. (10500 – 12500 MHz)
Impedance	50 Ω

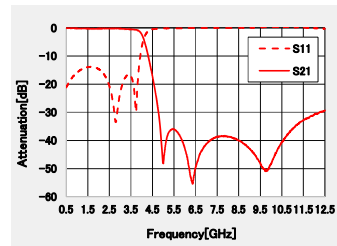

TSL1N18D1G68LV0DTT

Pass band frequency	617 – 2690 MHz 0.2 dB max. (-40~+85°C)
Return loss. at 617 – 2690 MHz	10 dB min.
Attenuation	25 dB min. (5150 – 5950 MHz)
Impedance	50 Ω

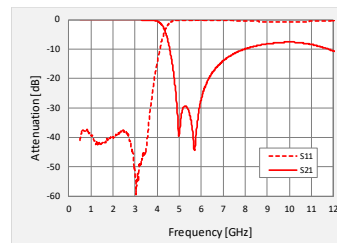

TSH1N18D2G49LS0FBT

Pass band frequency	2300 – 2690 MHz
Insertion loss at 2300 – 2690 MHz	1.5 dB max. (-40~+85°C)
V.S.W.R. at 2300 – 2690 MHz	2.0 max.
Attenuation	35 dB min. (1710 – 1880 MHz)
Impedance	50 Ω

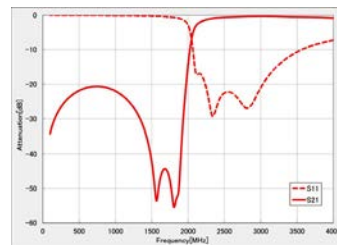

TSD1N18D2G45NS030T

Low band	
Pass band frequency 1	1558 – 1610 MHz
Pass band frequency 2	2400 – 2500 MHz
Insertion loss at Pass band 1	0.50 dB max. (-40~+85°C)
Insertion loss at Pass band 2	0.60 dB max. (-40~+85°C)
V.S.W.R. at Pass band	2.0 dB max.
Attenuation	24 dB min. (4800 – 4900 MHz) 26 dB min. (4900 – 6000 MHz)
Impedance	50 Ω
High band	
Pass band frequency	4900 – 5950 MHz
Insertion loss at Pass band	0.80 dB max. (-40~+85°C)
V.S.W.R. at Pass band	2.0 dB max.
Attenuation	32 dB min. (30 – 2700 MHz)
Impedance	50 Ω

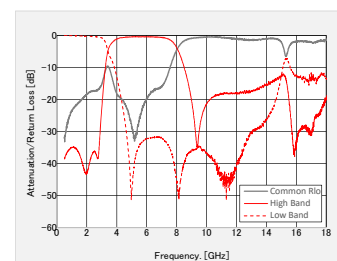

ELECTRICAL CHARACTERISTICS / TYPICAL CHARACTERISTICS

TSD1N21A829LNS0G2T

Low band	
Pass band frequency	698 - 960 MHz
Insertion loss at 698 - 960 MHz	0.27 dB max. (+25°C)
	0.32 dB max. (-40~+85°C)
V.S.W.R. at 698 - 960 MHz	2.0 max.
Attenuation	13 dB min. (1710 - 2690 MHz)
Impedance	50 Ω

High band	
Pass band frequency	1710 - 2690 MHz
Insertion loss at 1710 - 2690 MHz	0.45 dB max. (+25°C)
	0.55 dB max. (-40~+85°C)
V.S.W.R. at 698 - 960 MHz	2.0 max.
Attenuation	19 dB min. (698 - 960 MHz)
Impedance	50 Ω

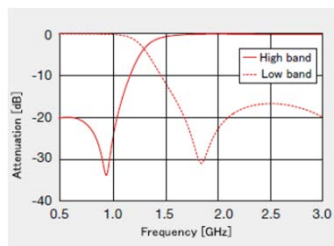

TSD1N18B829MLV0D4T/TSD1N18B829MLV0CZT

Low band	
Pass band frequency	617 - 960 MHz
Insertion loss at 617 - 960 MHz	0.85 dB max. (-40~+85°C)
V.S.W.R. at 617 - 960 MHz	2.0 max.
Attenuation	22 dB min. (1427 - 1710 MHz)
	25 dB min. (1710 - 2690 MHz)
	25 dB min. (5150 - 5925 MHz)
Impedance	50 Ω

High band	
Pass band frequency	1427 - 2690 MHz
Insertion loss at 1427 - 2690 MHz	1.05 dB max. (-40~+85°C)
V.S.W.R. at 1427 - 2690 MHz	2.0 max.
Attenuation	15 dB min. (617 - 699 MHz)
	17 dB min. (699 - 960 MHz)
Impedance	50 Ω

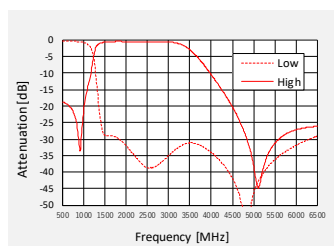

TSD1N18B1G79LS0FHT

Pass band frequency	1710 - 1920 MHz
Insertion loss at 1710 - 1880 MHz	0.6 dB max. (-40~+85°C)
Insertion loss at 1880 - 1920 MHz	0.7 dB max. (-40~+85°C)
V.S.W.R. at 617 - 960 MHz	2.0 max.
Attenuation	15 dB min. (2496 - 2690 MHz)
Impedance	50 Ω

High band	
Pass band frequency	2496 - 2690 MHz
Insertion loss at 2496 - 2690 MHz	0.8 dB max. (-40~+85°C)
V.S.W.R. at 1427 - 2690 MHz	2.0 max.
Attenuation	15 dB min. (1710 - 1880 MHz)
	15 dB min. (1880 - 1920 MHz)
Impedance	50 Ω

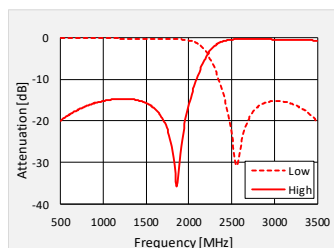

TSD1N21A829MLV0H9T/TSD1N21A829MLV0JTT

Pass band frequency 1	617 - 960 MHz
Pass band frequency 2	1427 - 5925 MHz
Impedance	50 Ω

TSD1M15H829MLM0DZT

Pass band frequency 1	699 - 960 MHz
Pass band frequency 2	1710 - 2690 MHz
Impedance	50 Ω

TSD1N21A1G95LV0ENT

Pass band frequency 1	1427 - 2200 MHz
Pass band frequency 2	2496 - 5000 MHz
Impedance	50 Ω

TSD1N21C1G70LV0CLT/TSD1N21C1G70LV0HUT

Pass band frequency 1	699 - 2690 MHz
Pass band frequency 2	3300 - 5000 MHz
Impedance	50 Ω

ELECTRICAL CHARACTERISTICS / TYPICAL CHARACTERISTICS

TSC4N18F1G69NS0B1T

Pass band frequency	699 - 2690 MHz
Insertion loss at 699 - 960 MHz	0.15 dB max. (+40~+85°C)
	0.1 dB max. (+15~+35°C)
Insertion loss at 1000 - 2025 MHz	0.1 dB max. (-20~+15°C)
	0.25 dB max. (+40~+85°C)
Insertion loss at 2110 - 2690 MHz	0.2 dB max. (+15~+35°C)
	0.28 dB max. (-20~+15°C)
Ripple	0.38 dB max. (+40~+85°C)
	0.28 dB max. (+15~+35°C)
	0.28 dB max. (-20~+15°C)
	0.1 dB max. (699 - 746 MHz)
	0.1 dB max. (791 - 862 MHz)
RF Coupling	0.1 dB max. (824 - 960 MHz)
	0.1 dB max. (1710 - 2170 MHz)
	0.1 dB max. (2500 - 2690 MHz)
	28.1~29.5 dB (699MHz)
	25.8~27.2 dB (915MHz)
	20.7~22.1 dB (1710MHz)
	19.9~21.3 dB (1880MHz)
19.3~20.7 dB (2025MHz)	
Coupling ratio mismatch between Coupler branch 1 and Coupler branch 2	18.3~19.7 dB (2300MHz)
	17.1~18.5 dB (2690MHz)
	-1~1 dB (699 - 2690 MHz)
	18 dB min. (699 - 2690 MHz)
	Impedance

TSC1N18D1G68NC0AAT

Pass band frequency	698 - 2690 MHz
Insertion loss at 699 - 2690 MHz	0.25 dB max. (+25°C)
	0.30 dB max. (-40~+85°C)
RF Coupling	26.5~29.0 dB (698MHz)
	24.0~27.0 dB (915MHz)
	21.5~24.5 dB (1710MHz)
	21.5~24.5 dB (2025MHz)
	21.5~24.5 dB (2300MHz)
	21.5~25.5 dB (2690MHz)
Isolation	35 dB min. (698 - 2690 MHz)
Impedance	50 Ω

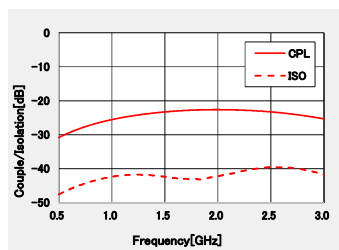

Ceramic RF Devices

PACKAGING

① Minimum Quantity

Type	L × W × T	Embossed tape / Paper tape [pcs]
TSD1N21A	2.0 × 1.25 × 1.0	3000
TST1N22D	2.5 × 2.0 × 1.0	
TSB1N18F	1.6 × 0.8 × 0.5	4000
TSB1N18D	1.6 × 0.8 × 0.65	
TSB1N21D	2.0 × 1.25 × 0.65	5000
TSC1N18D	1.6 × 0.8 × 0.65	
TSD1N21C	2.0 × 1.25 × 0.7	
TSD1N18B	1.6 × 0.8 × 0.8	
TSD1N18D	1.6 × 0.8 × 0.65	
TSH1N18D	1.6 × 0.8 × 0.65	
TSC4N18F	1.6 × 0.8 × 0.5	8000
TSB1N15H	1.0 × 0.5 × 0.4	10000
TSD1N15H	1.0 × 0.5 × 0.4	
TSL1M15H	1.0 × 0.5 × 0.4	

② Tape Material

● Embossed Tape

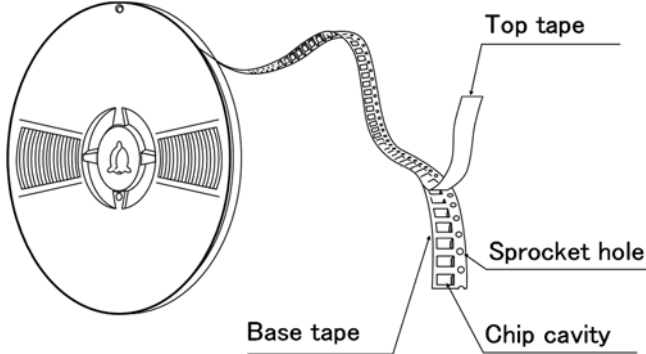

● Card Board Carrier Tape

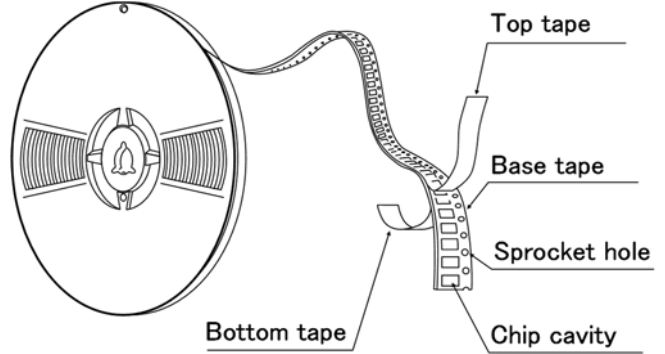

Chip Filled

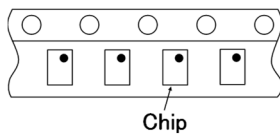

③ Taping Dimensions

● Embossed tape 0.315 inches wide

Unit: mm (inch)

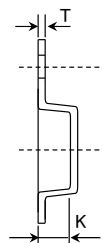
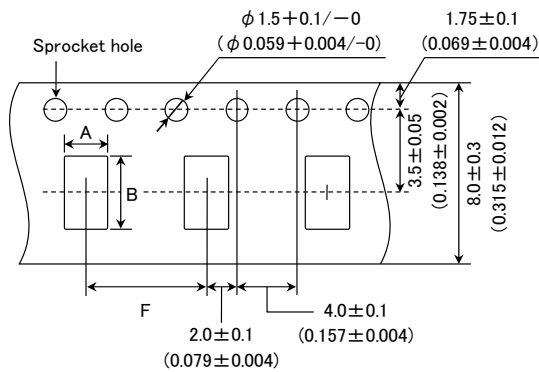

▶ This catalog contains the typical specification only due to the limitation of space. When you consider the purchase of our products, please check our specification. For details of each product (characteristics graph, reliability information, precautions for use, and so on), see our Web site (<http://www.ty-top.com/>).

Type	Chip cavity		Insertion Pitch	Tape Thickness max.	
	A	B		K	T
TSB1N21D	1.45±0.2 (0.057±0.008)	2.25±0.2 (0.089±0.008)	4.0±0.1 (0.157±0.004)	0.95 Max (0.037 Max)	0.3 (0.012)
TSD1N21A	1.45±0.2 (0.057±0.008)	2.25±0.2 (0.089±0.008)	4.0±0.1 (0.157±0.004)	1.1 Max (0.043 Max)	0.3 (0.012)
TSD1N21C	1.45±0.2 (0.057±0.008)	2.25±0.2 (0.089±0.008)	4.0±0.1 (0.157±0.004)	0.95 Max (0.037 Max)	0.3 (0.012)
TDT1N22D	2.3±0.1 (0.091±0.004)	2.7±0.1 (0.106±0.004)	4.0±0.1 (0.157±0.004)	0.9 Max (0.035 Max)	0.35 Max (0.014)

Unit: mm (inch)

● Paper tape 0.315 inches wide

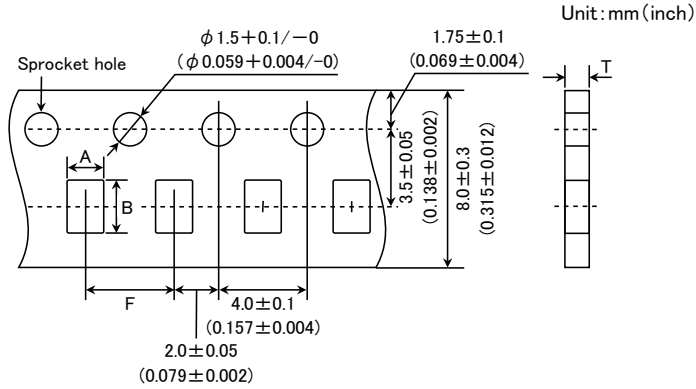

Type	Chip cavity		Insertion Pitch	Tape Thickness max.
	A	B		
TSB1N18F	1.00±0.05 (0.039±0.002)	1.80±0.05 (0.071±0.002)	4.0±0.1 (0.157±0.004)	0.55 (0.022)
TSC4N18F	1.00±0.05 (0.039±0.002)	1.80±0.05 (0.071±0.002)	4.0±0.1 (0.157±0.004)	0.55 (0.022)
TSB1N18D	0.95±0.05 (0.037±0.002)	1.80±0.05 (0.071±0.002)	4.0±0.1 (0.157±0.004)	0.80 (0.031)
TSC1N18D	0.95±0.05 (0.037±0.002)	1.80±0.05 (0.071±0.002)	4.0±0.1 (0.157±0.004)	0.55 (0.022)
TSD1N18D	0.95±0.05 (0.037±0.002)	1.80±0.05 (0.071±0.002)	4.0±0.1 (0.157±0.004)	0.90 (0.035)
TSD1N18D	0.95±0.05 (0.037±0.002)	1.80±0.05 (0.071±0.002)	4.0±0.1 (0.157±0.004)	0.80 (0.031)
TSH1N18D	0.95±0.05 (0.037±0.002)	1.80±0.05 (0.071±0.002)	4.0±0.1 (0.157±0.004)	0.80 (0.031)
TSL1N18D	0.95±0.05 (0.037±0.002)	1.80±0.05 (0.071±0.002)	4.0±0.1 (0.157±0.004)	0.80 (0.031)
TSB1N15H	0.62±0.03 (0.024±0.001)	1.12±0.03 (0.044±0.001)	2.0±0.05 (0.079±0.002)	0.45 (0.018)
TSD1N15H	0.62±0.03 (0.024±0.001)	1.12±0.03 (0.044±0.001)	2.0±0.05 (0.079±0.002)	0.45 (0.018)
TSL1M15H	0.62±0.03 (0.024±0.001)	1.12±0.03 (0.044±0.001)	2.0±0.05 (0.079±0.002)	0.45 (0.018)

Unit: mm (inch)

► This catalog contains the typical specification only due to the limitation of space. When you consider the purchase of our products, please check our specification. For details of each product (characteristics graph, reliability information, precautions for use, and so on), see our Web site (<http://www.ty-top.com/>).

④ Leader and Blank Portion

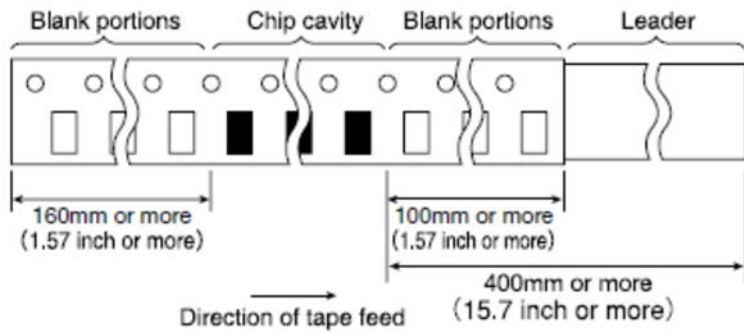

⑤ Reel size

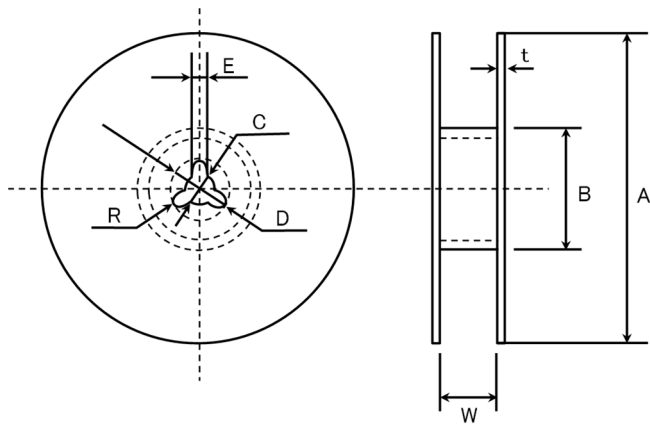

A	B	C	D	E	R
$\phi 178 \pm 2.0$ ($\phi 7.01 \pm 0.079$)	$\phi 50 \text{ min.}$ ($\phi 1.97 \text{ min.}$)	$\phi 13.0 \pm 0.2$ ($\phi 0.512 \pm 0.008$)	$\phi 21.0 \pm 0.8$ ($\phi 0.827 \pm 0.031$)	2.0 ± 0.5 (0.079 ± 0.020)	1.0
	t	W			
8mm width tape (0.315 inches width)	2.5max. (0.098max.)	10 ± 1.5 (0.394 ± 0.059)			

Unit: mm (inch)

⑥ Top Tape Strength

The top tape requires a peel-off force of 0.1~0.7N in the direction of the arrow as illustrated below.

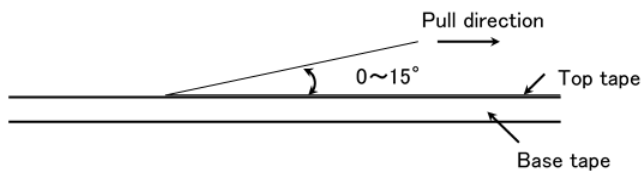

Ceramic RF Devices for General Electronic Equipment for Consumer

RELIABILITY DATA

1. Operating Temperature Range

Specified Value : $-40 \sim +85^{\circ}\text{C}$

2. Storage Temperature Range

Specified Value : $-40 \sim +85^{\circ}\text{C}$

Test Methods and Remarks : ※Note : -20 to $+40^{\circ}\text{C}$ in taped packaging

3. Resistance to Flexure of Substrate

Specified Value : No mechanical damage.

Test Methods and Remarks :
 Warp : 2mm
 Testing board : Glass epoxy-resin substrate
 Thickness : 0.8mm

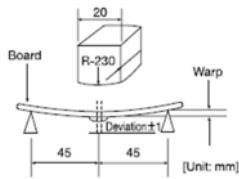

4. Adhesion of Electrode

Specified Value : Characteristics : shall satisfy the electrical characteristics.
 Appearance : No significant abnormality.

Test Methods and Remarks :
 Applied force : 5N
 Duration : 10 sec.

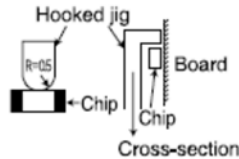

5. Solderability

Specified Value : 75% or more of immersed surface of terminal electrode shall be covered with fresh solder.

Test Methods and Remarks :
 Solder temperature : $240 \pm 5^{\circ}\text{C}$
 Duration : 3 ± 1 sec
 Preconditioning : Immersion into flux.
 Immersion and Removal speed : 25mm/sec.

6. Resistance to Solder Heat

Specified Value : Characteristics : shall satisfy the electrical characteristics.
 Appearance : No significant abnormality.

Test Methods and Remarks :
 Preheating : 150°C for 2 min.
 Solder temperature : $260 \pm 5^{\circ}\text{C}$
 Duration : 5 ± 0.5 sec.
 Preconditioning : Immersion into flux.
 Immersion and Removal speed : 25mm/sec.
 Recovery : 2 to 3hrs of recovery under the standard condition after the removal from test chamber.

7. Thermal Shock

► This catalog contains the typical specification only due to the limitation of space. When you consider the purchase of our products, please check our specification. For details of each product (characteristics graph, reliability information, precautions for use, and so on), see our Web site (<http://www.ty-top.com/>).

Specified Value	Characteristics : shall satisfy the electrical characteristics. Appearance : No significant abnormality.															
Test Methods and Remarks	According to JIS C60068-2-14. Conditions for 1 cycle															
	<table border="1"> <thead> <tr> <th>Step</th> <th>Temperature (°C)</th> <th>Duration (min)</th> </tr> </thead> <tbody> <tr> <td>1</td> <td>-40±3</td> <td>30±3</td> </tr> <tr> <td>2</td> <td>Room Temperature</td> <td>Within 3</td> </tr> <tr> <td>3</td> <td>85±2</td> <td>30±3</td> </tr> <tr> <td>4</td> <td>Room Temperature</td> <td>Within 3</td> </tr> </tbody> </table>	Step	Temperature (°C)	Duration (min)	1	-40±3	30±3	2	Room Temperature	Within 3	3	85±2	30±3	4	Room Temperature	Within 3
	Step	Temperature (°C)	Duration (min)													
	1	-40±3	30±3													
	2	Room Temperature	Within 3													
3	85±2	30±3														
4	Room Temperature	Within 3														
Number of cycles : 100																
Mounting method : Soldering onto PC board. Recovery : 2 to 3hrs of recovery under the standard condition after the removal from test chamber.																

8. Humidity (steady state)

Specified Value	Characteristics : shall satisfy the electrical characteristics. Appearance : No significant abnormality.
Test Methods and Remarks	Temperature : +85±2°C Humidity : 85±5%RH Duration : 1000 hrs Recovery : 2 to 3hrs of recovery under the standard condition after the removal from test chamber.

9. High temperature life test

Specified Value	Characteristics : shall satisfy the electrical characteristics. Appearance : No significant abnormality.
Test Methods and Remarks	Temperature : +85±2°C Duration : 1000 hrs Recovery : 2 to 3hrs of recovery under the standard condition after the removal from test chamber.

10. Low temperature life test

Specified Value	Characteristics : shall satisfy the electrical characteristics. Appearance : No significant abnormality.
Test Methods and Remarks	Temperature : -40±2°C Duration : 1000 hrs Recovery : 2 to 3hrs of recovery under the standard condition after the removal from test chamber.

Note on standard condition:

“standard condition” referred to herein is defined as follows :
5 to 35°C of temperature, 45 to 85% relative humidity and 86 to 106kPa of air pressure.

When there are questions concerning measurement result :
In order to provide correlation data, the test shall be conducted under condition of 20±2°C of temperature, 60 to 70% relative humidity and 86 to 106kPa of air pressure.

Unless otherwise specified, all the tests are conducted under the “standard condition”.

Ceramic RF Devices

PRECAUTIONS

1. PCB Design

◆ Land pattern design

Land pattern dimension examples

	TSD1M15H/TSL1N15H LGA 6Pins type	TSB1N15H/TSL1N15H Side 4Pins type	TSB1N18F Side 4Pins type	TSB1N18D/TSL1N18D /TSH1N18D LGA 3Pins type
Technical considerations				
	Unit: mm	Unit: mm	Unit: mm	Unit: mm
	TSD1N18B LGA 6Pins type	TSD1N18D/TSL1N18D /TSC1N18D Side 6Pins type	TSC4N18F Side 8Pins type	TSB1N21D LGA 3Pins type
	Unit: mm	Unit: mm	Unit: mm	Unit: mm
TSD1N21A829MLS0G2T /TSD1N21C LGA 6Pins type	TSD1N21 LGA 6Pins type	TST1N22D LGA 9Pins type		
Unit: mm	Unit: mm	Unit: mm		

2. Soldering

◆ Conditions for Reflow soldering (for reference)

• Pb Free Reflow Profile

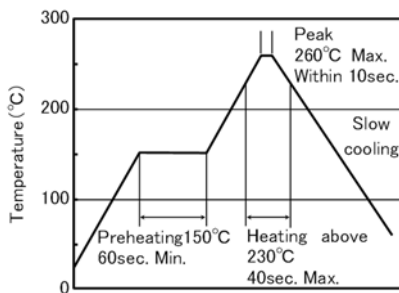

- ※ Components should be preheated to within 100 to 130°C from soldering temperature.
- ※ Assured to be reflow soldering for 2 times.

Note : The above profiles are the maximum allowable soldering condition, therefore these profiles are not always recommended.

3. Storage conditions

Precautions

◆ Storage conditions

1. The Products must not be used in the following environments :

- exposure to special gases such as (C12, NH3, SOx, NOx)
- exposure to volatile gas or inflammable gas
- exposure to a lot of dust
- exposure to water or condensation
- exposure to direct sunlight or freezing

2. The Products should be kept in the following conditions :

- Temperature : $-10\sim +40^{\circ}\text{C}$
- Humidity : 15~85%RH max.

3. The products should be used within 6 months after delivery. In case of storage over 6 months, solderability shall be checked before actual usage.

■ Please contact of our offices for further details of specifications.

All of the standard values listed here are subject to change without notice.

Therefore, please check the specifications carefully before use.